



Kentucky Trailer
6370 Emerald Pkway, Ste.106
Monee, IL 60449
(708) 235-2800 main number
(708) 235-2002 fax

Custom Specialty Vehicles



Site Planning Guide

Siemens

Mobile CT System

48' L x 8'-6" W x 13'-6" H USA Unit

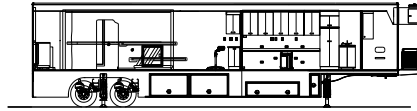

© 2018 Advanced Mobility

This guide contains confidential information of Advanced Mobility.

You may not copy it or any part of it without the written permission of Advanced Mobility.

This manual may be used only by you, and only for the purposes for which it was intended. You may not disclose this manual or the confidential information it contains outside of your company.

If you wish to copy any part of this manual, or to use it other than as described above, you must contact Advanced Mobility seeking permission to do so.

North America

Corporate Headquarters

Advanced Mobility
500 Crossings
University Park IL.
60484
USA
(001) 708.596.5066

Europe

Advanced Mobility, Ltd.
Unit 17, Nelson Way
Tuscum Trading Estate,
Camberley, Surrey
GU15 3DH
United Kingdom
(44) 01276.64490

Buys Ballotstraat 6
3261 LA Oud-Beijerland, Holland
+31 (0) 186-614322
Fax. +31 (0) 186-619367
E-mail: smit@smit-mobile.nl



Kentucky Trailer
6370 Emerald Pkway, Ste.106
Monee, IL 60449
(708) 235-2800 main number
(708) 235-2002 fax

Custom Specialty Vehicles



List of Revisions

Revisions

00

Initial release

MAY. 2018

Notice

In accordance with our policy of continued product improvement, Advanced Mobility reserves the right to make changes in the equipment, design, specifications, and materials of the product described herein. Any problems or questions related to the components or systems covered in this booklet may be directed to:

Advanced Mobility
Attention: Service Department
500 Crossings
University Park IL.
60484
USA

Telephone: (001) 800.839.0630 (24/7 Service)
Fax: (001) 708.596.2480

<http://www.amstcorp.com>



Kentucky Trailer
6370 Emerald Pkway, Ste.106
Monee, IL 60449
(708) 235-2800 main number
(708) 235-2002 fax

Custom Specialty Vehicles



Table of Contents

Introduction 5

Warnings & Safety Alert Conventions 5

Support Pad Requirements 6

Trailer Weight 6
Recommended Support Pad Requirements 6
Support Pad Depth 6
Support Pad Levelness 6
Recommended Service Pad 6
Electro Magnetic Interference 6
Vehicle Access 6
Recommended Attachment to the Facility 7
Air Conditioning Air Flow Clearance 7
Swing Clearance Note 7

Radiation Shielding Requirements 8

Radiation Shielding 8
Radiation Field Information 8

Customer Power Requirements 9

Lockout/Tagout 9
Electrical Service 9
Configuration 9
Load Regulation at Line Frequency 9
Frequency 9
Phase Balance 9
Maximum Voltage Variation 9
Connector Type 9
Customer Facility 10
Input Power 10
Power Source Monitoring (Facility Only) 10

Telephone and Data Service Requirements 13

Telephone Service 13
Data Service 13

Water Requirements 14

Water Supply Tank 14
Waste Water Tank 14



Kentucky Trailer
6370 Emerald Pkway, Ste.106
Monee, IL 60449
(708) 235-2800 main number
(708) 235-2002 fax

Custom Specialty Vehicles



Table of Figures

Figure 2: Right Side Elev.....	15
Figure 3: Left Side Elevation	16
Figure 4: Radiation Shielding Plan View	17
Figure 6: Russellstoll Receptacle, Service Disconnect	19
Figure 7: Russellstoll Receptacle Chart	20
Figure 8: Turning Requirement	21



Kentucky Trailer
6370 Emerald Pkway, Ste.106
Monee, IL 60449
(708) 235-2800 main number
(708) 235-2002 fax

Custom Specialty Vehicles



Introduction

The purpose of this document is to provide the basic information needed for site planning. For specific information not contained in this document, please contact Advanced Mobility.

The mobile unit requires sufficient room to be maneuvered and positioned for setup and takedown.

The mobile unit has many storage compartments and service doors that require access during these procedures as well as during operation. The expanding wall sections, patient lift, entry stairs, and optional platform require additional space on the right side of the mobile unit. Refer to the drawings provided for actual locations of doors, patient lift, and stair sizes and locations.

Warnings & Safety Alert Conventions

Three types of statements are used throughout this document to warn the operator of potential situations. Always read these statements carefully and take the appropriate safety precautions to ensure a safe environment for all personnel and all property. The statements are as follows:



The term "WARNING" is used whenever potential personal injury or death situations exist, requiring correct procedures / practices for prevention.



The term "CAUTION" is used whenever potential damage to equipment exists, requiring correct procedures / practices for prevention.



The term "IMPORTANT" is used whenever information exists that requires special attention to procedures to ensure proper operation of the equipment or to prevent its possible failure.



Kentucky Trailer
6370 Emerald Pkway, Ste.106
Monee, IL 60449
(708) 235-2800 main number
(708) 235-2002 fax

Custom Specialty Vehicles



Support Pad Requirements

IMPORTANT

If other modalities utilize the same support pad, it is recommended that non-ferrous reinforcement materials be used for pad reinforcement.

IMPORTANT

Siemens must approve plans for pad construction.

The following is a list of recommendations and requirements for a concrete support pad. However, due to varying site conditions, the actual pad design should be prepared by an appropriately licensed structural or architectural engineer.

Trailer Weight

The weight of the trailer should be considered in the design of the support and service pads. The overall weight of the trailer is approximately 48,520 lbs. The weight on the rear axles is approximately 32,780 lbs. The weight on the King Pin is approximately 15,740 lbs.

Recommended Support Pad Requirements

The measurements for the recommended support pad are as follows, 10'-9" x 43'-3". The cross hatching as shown on [1](#) and [Figure 2: Right Side Elev](#) represents the recommended support pad.

Support Pad Depth

Recommendations for the width and length of the pad are given above. Based upon the existing site conditions, the depth should be determined by a local contractor.

Support Pad Levelness

In order to ensure proper operation of the Siemens CT system, the support pad(s) must be level and the deviation must not exceed .125" in 10'-0."

Recommended Service Pad

The measurements for the recommended service pad are as follows, 20' x 57'. This will allow full service access to the mobile unit. The recommended service pad is shown on and

[Figure 2: Right Side Elev](#).

Electro Magnetic Interference

The ambient static magnetic field within the region of the gantry should not exceed 1 Gauss (10⁻⁴ Tesla).

Vehicle Access

A firm, level surface is required around the mobile unit in order to provide access to the site, patient access to the mobile unit, and servicing of the mobile unit.



Kentucky Trailer
6370 Emerald Pkway, Ste.106
Monee, IL 60449
(708) 235-2800 main number
(708) 235-2002 fax

Custom Specialty Vehicles



Recommended Attachment to the Facility

An inflatable air bag or soft seal is recommended at the point of connection from the unit to the facility. Fixed or solid connections may hinder imaging quality. Contact the local Siemens representative prior to construction if the proposed connection varies from the recommended.

Air Conditioning Air Flow Clearance

The following clearances for acceptable air conditioning condenser air flow have been established between wall-mounted equipment and opposing units or surfaces for maximum capacity, lowest operating cost, satisfactory operation of ventilation packages, and longest service life

- Unit discharging against opposing (facing) unit – 20 feet from coil grill to coil grill
- Unit discharging against a wall or essentially solid barrier – 15 feet from coil grill to wall.

Swing Clearance Note

Please verify the actual dimensions of the rearmost projections on the cab of your tractor to the centerline of tandem suspension or centerline of the fifth wheel plate on your tractor. Refer to [Figure 8: Turning Requirement](#) for proper tractor sizing information.



Kentucky Trailer
6370 Emerald Pkway, Ste.106
Monee, IL 60449
(708) 235-2800 main number
(708) 235-2002 fax

Custom Specialty Vehicles



Radiation Shielding Requirements

Radiation Shielding

IMPORTANT

Radiation exposure limits must be in accordance with all local, state, and federal requirements. It is the responsibility of the customer to perform a proper radiation survey in order to determine the exclusion zone.

Care should be taken when determining a site location. Factors such as shielding design, proximity to buildings, and occupancy of the surrounding areas must be considered. An exclusion zone around the mobile unit may be necessary. Refer to [Figure 4: Radiation Shielding Plan View](#) for additional information.

Radiation Field Information

It is the responsibility of the customer to ensure a safe environment with respect to the radiation field. Due to radioactivity levels associated with diagnostic procedures used in CT scanning, an exclusion zone must be maintained while in use.

Customer must contact their local Radiation Safety Operation Official for the federal, state, and local guidelines and must comply with these safety requirements.

Operator needs to make their own exposure dose measurements to include radiation from patients when determining the outside "Keep Away Zone" (chained-off area).



Kentucky Trailer
6370 Emerald Pkway, Ste.106
Monee, IL 60449
(708) 235-2800 main number
(708) 235-2002 fax

Custom Specialty Vehicles



Customer Power Requirements



It is the operator's responsibility to verify that the shore power receptacle is of the same type and voltage as the connection that is supplied by Advanced Mobility. Failure to do this can result in injury or death to the operator of the mobile unit as well as irreparable damage to the mobile unit.



The standard connector for the unit is a Russellstoll DS 2504 MP000/DF2032, 480V 200A Plug. If an existing site currently implements a different connector or connector configuration, please contact Advanced Mobility in order to arrange for a compatible power connector before the unit leaves the facility.

Lockout/Tagout

A Lockout/Tagout provision in accordance with OSHA Standard 1910.147 is required. The facility shore power disconnect device must be located within 40'- 0" of the unit and must provide for an effective lockout/tagout to facilitate safe service and maintenance of the unit.

Electrical Service

A single electrical power source is required for operation of the CT system. 3/PE 480-Vac service fused at 150 amperes.

Configuration

Three phase, Five wire, wye connection, with ground. (5 wire 3/PE 480-Vac)

Load Regulation at Line Frequency

Wires are to be sized such that the line voltage drops from the power source to the mobile unit is less than 2.5% of the nominal voltage for the rated load of the mobile unit.

Frequency

60Hz \pm 2.0Hz.

Phase Balance

The phase balance is 3% maximum of lowest phase-to-phase voltage.

Maximum Voltage Variation

The maximum voltage variation is \pm 10% from a nominal steady state (under the worst case conditions of line voltage).

Connector Type

The mobile unit is supplied with a 50'-0" power cable and male conductor. Unless otherwise specified, the connector type is a Russellstoll DS2504MP000/DF2032, 480V 200A rated plug.



Kentucky Trailer
6370 Emerald Pkway, Ste.106
Monee, IL 60449
(708) 235-2800 main number
(708) 235-2002 fax

Custom Specialty Vehicles



Customer Facility

The customer facility must have the matching receptacle as specified in [Figure 6: Russellstoll Receptacle, Service Disconnect](#) and [Figure 7: Russellstoll Receptacle Chart](#). Unless otherwise specified, the receptacle type to be used must be a Russellstoll DF2504FRAB0 female connector.

Input Power

- Frequency: 60Hz \pm 2.0 Hz
- Regulation: Load regulation must not exceed 2.5%.
- Phase Imbalance: The difference between the highest line-to-line voltage and lowest line-to-line voltage must not exceed 3% of the lowest line-to-line voltage.

Power Source Monitoring (Facility Only)

NOTE: Perform a power audit first.

A power analyzer should be used to check the proposed Mobile CT Series facility site power for average line voltage, surges, sags, reclosures, impulses, frequency and microcuts. A period that includes two weekends should be used to simulate several days of normal use. Analysis of the data and site history of any previous power problems with other X-ray systems or computer installations should be reviewed with your power and ground representative. Verify “brown-out” (low voltage) conditions, which may occur during summer months, will not exceed the allowable range.

Some analyzer models that are suitable for power monitoring are:

- Dranetz Model 658
- Dranetz Model 656A
 - BMI 3630
 - RPM

Mobile Grounding Requirements

Mobile Grounding Requirements

Special Ground Note

The mobile unit must have an earth driven ground rod within 5'-0" of the facility power receptacle. A grounding cable of a minimum #1/0 AWG must be connected between the grounding rod and the grounding pin of the facility power receptacle. Another cable to be kept as short as possible may also be connected between the ground stud on the Automatic Transfer Switch and an earth driven ground rod. See below. A separate grounding conductor must still be run with the phase conductors to the source of the power from the grounding pin of the hospital power receptacle in accordance with NEC 2002 Article 250-24.



Figure 1: Ground Connection



Kentucky Trailer
6370 Emerald Pkway, Ste.106
Monee, IL 60449
(708) 235-2800 main number
(708) 235-2002 fax

Custom Specialty Vehicles





Kentucky Trailer
6370 Emerald Pkway, Ste. 106
Monee, IL 60449
(708) 235-2800 main number
(708) 235-2002 fax

Custom Specialty Vehicles



Telephone and Data Service Requirements

Telephone Service

The mobile unit is supplied with two (2) telephone connections. The connector type that is used is a Hubbell model PH-6595 (inlet) with a model PH-6624 connector body.

The customer is required to purchase and install two (2) Hubbell all weather telephone connections, model PH-6597 for use at the site.

Two Hubbell model PH-6599 telephone-connecting cables are included with the mobile unit. The cables measure 50'-0" in length.

Data Service

The mobile unit is supplied with four (4) data line connections that utilize RJ-45 outlets.

The customer is required to purchase and install the data connection cables for use with the data line connections. The data line connections require a 50'-0" CAT-6E cable with RJ-45 connections.



Kentucky Trailer
6370 Emerald Pkway, Ste.106
Monee, IL 60449
(708) 235-2800 main number
(708) 235-2002 fax

Custom Specialty Vehicles



Water Requirements

IMPORTANT

During winter conditions, provisions must be made to ensure that water lines do not freeze because of weather conditions.

Water Supply Tank

A 15-gallon water supply tank is located on the right-side of the mobile unit in the underbody compartments, which supplies the HVAC system as well as the optional onboard sink.

The water supply tank can be filled from within the compartment by using the supplied adapter, or from the exterior of the mobile unit by using the connection on the underbody and the hose.

The drain for the water supply tank is located below the underbody compartment door. The drain valve is located in the underbody compartment.

Waste Water Tank

A 15-gallon wastewater tank is located on the right-side of the mobile unit in the underbody compartments to be used with the optional onboard sink.

The drain for the wastewater tank is located below the underbody compartment door. The drain valve is located in the underbody compartment.



Kentucky Trailer
 6370 Emerald Pkway, Ste. 106
 Monee, IL 60449
 (708) 235-2800 main number
 (708) 235-2002 fax

Custom Specialty Vehicles

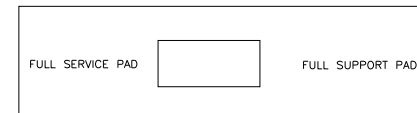
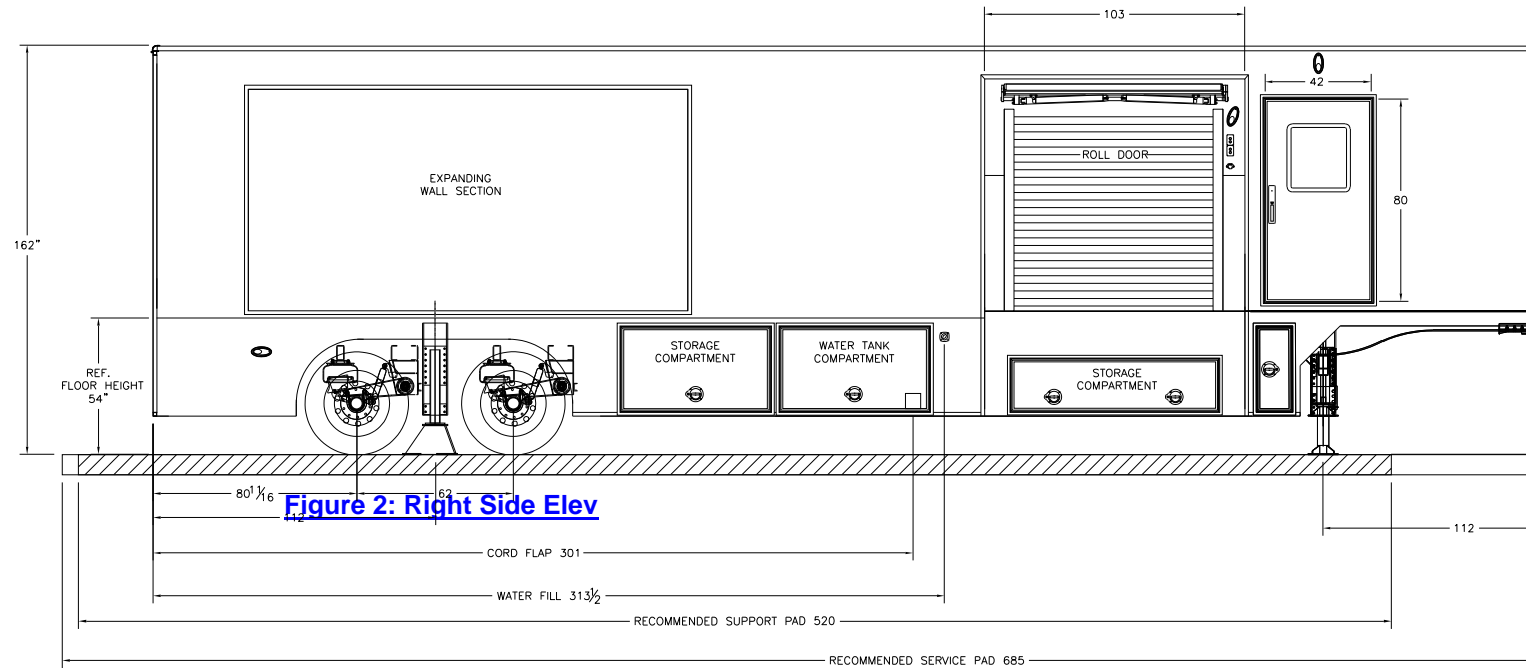



Kentucky Trailer
 6370 Emerald Pkway, Ste. 106
 Monee, IL 60449
 (708) 235-2800 main number
 (708) 235-2002 fax

Custom Specialty Vehicles

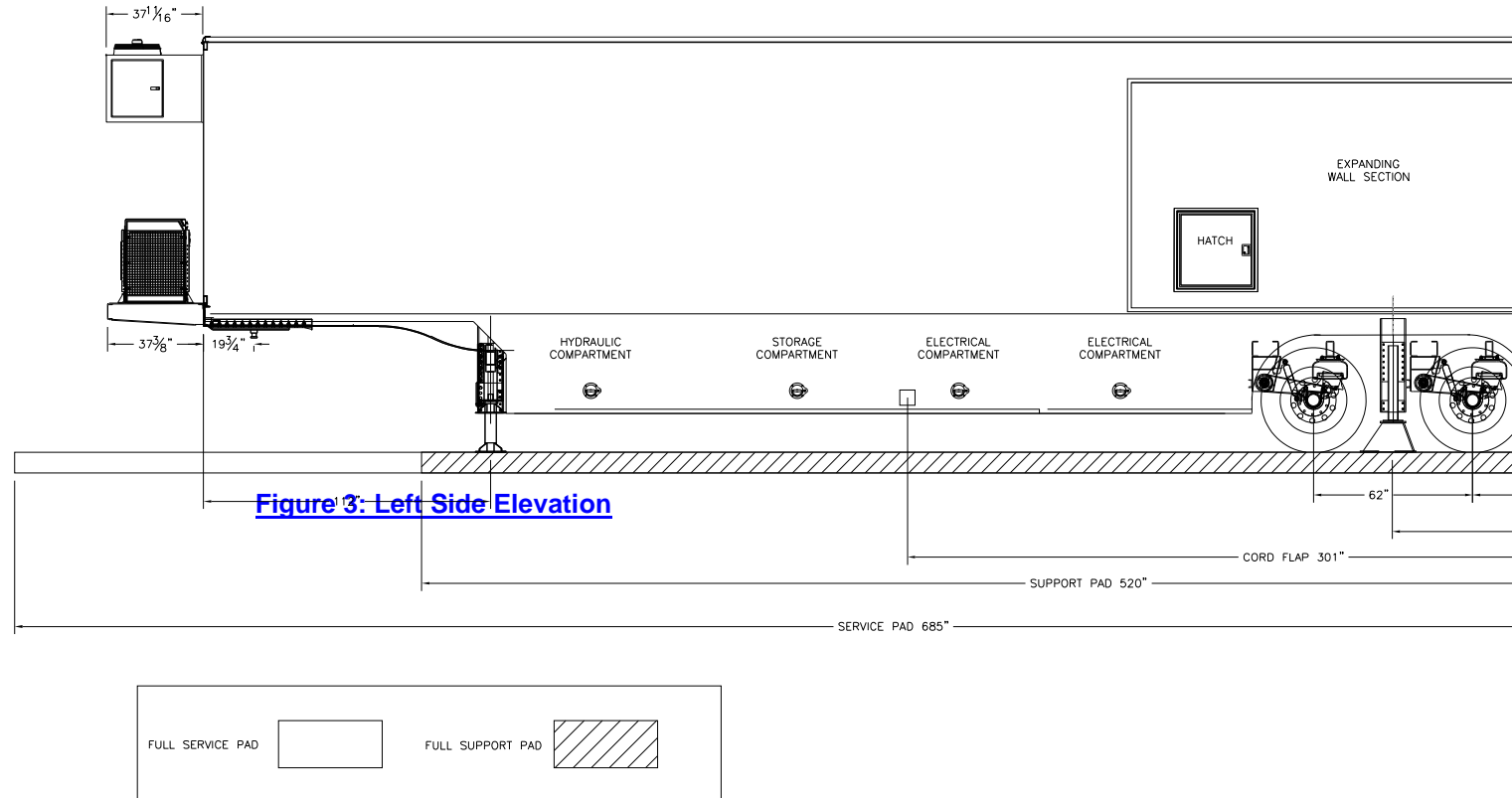

Figure 3: Left Side Elevation



Kentucky Trailer
 6370 Emerald Pkway, Ste.106
 Monee, IL 60449
 (708) 235-2800 main number
 (708) 235-2002 fax

Custom Specialty Vehicles

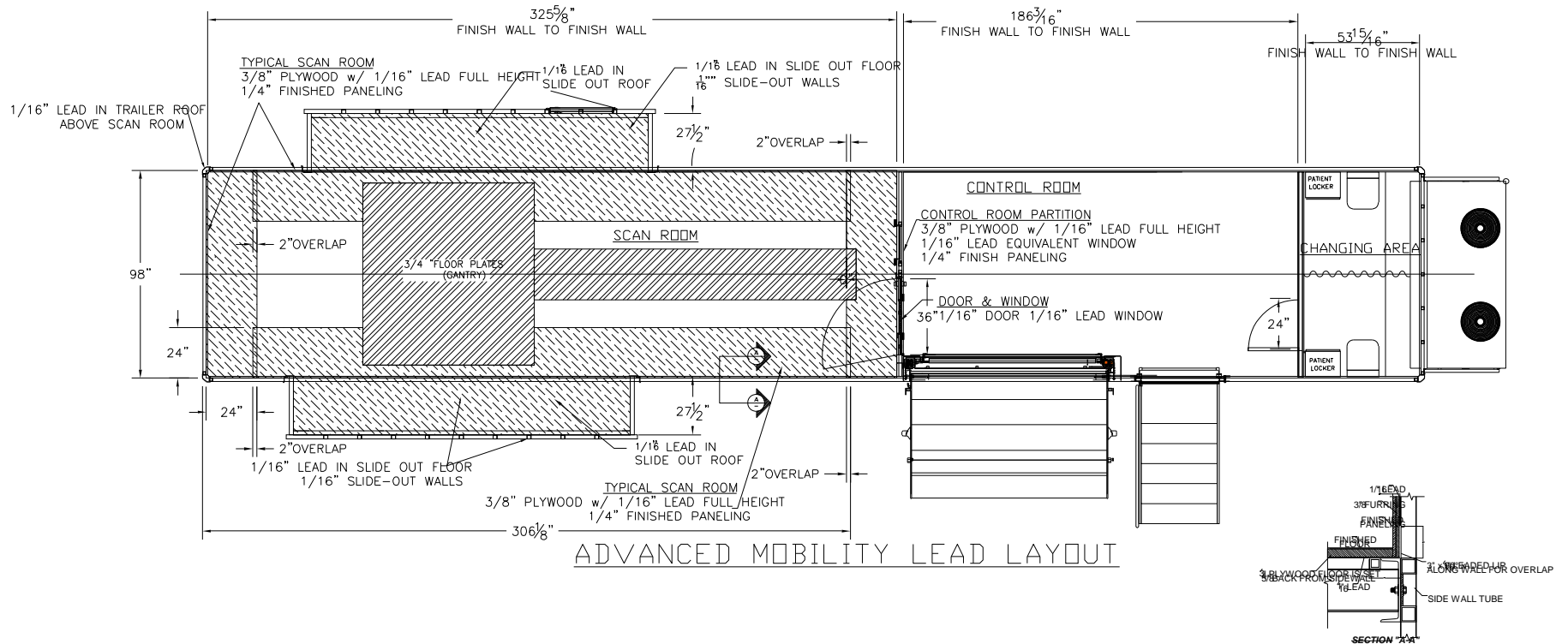

Figure 4: Radiation Shielding Plan View



Kentucky Trailer
 6370 Emerald Pkway, Ste.106
 Monee, IL 60449
 (708) 235-2800 main number
 (708) 235-2002 fax

Custom Specialty Vehicles



Figure 5: Stair / Lift / Wall Elevation

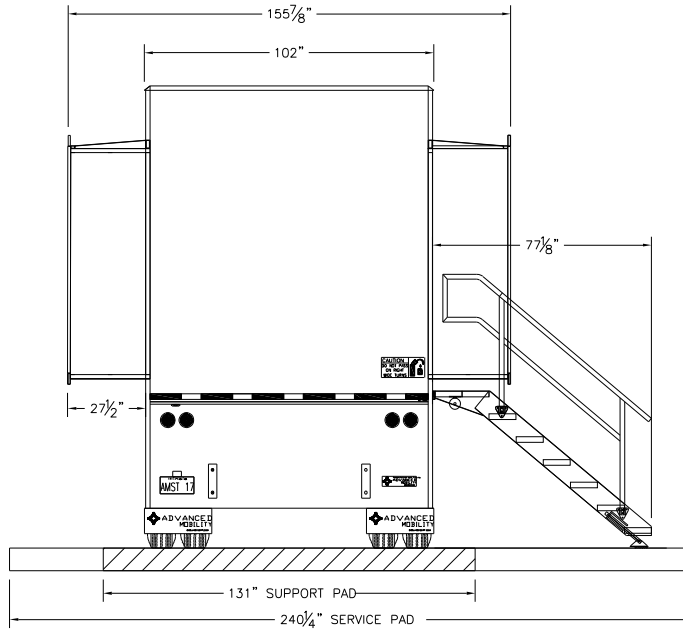

REAR ELEVATION VIEW

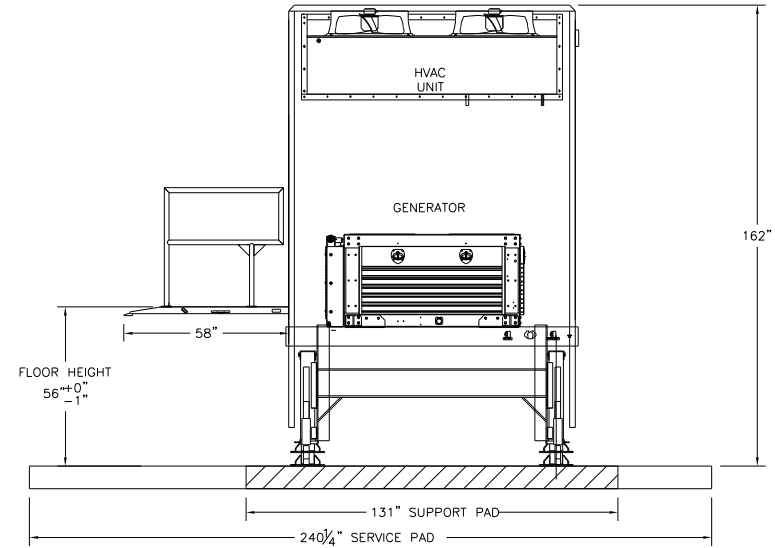

FRONT ELEVATION VIEW

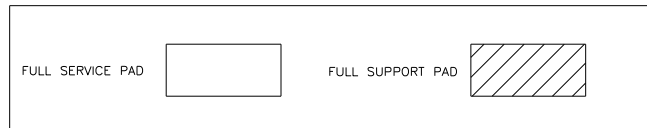



Kentucky Trailer
 6370 Emerald Pkway, Ste.106
 Monee, IL 60449
 (708) 235-2800 main number
 (708) 235-2002 fax

Custom Specialty Vehicles



RUSSELLSTOLL RECEPTACLE / DISCONNECT DIAGRAM

480 VOLT AC - 3 PHASE WALL MOUNTED RECEPTACLE (SUPPLIED BY CUSTOMER)

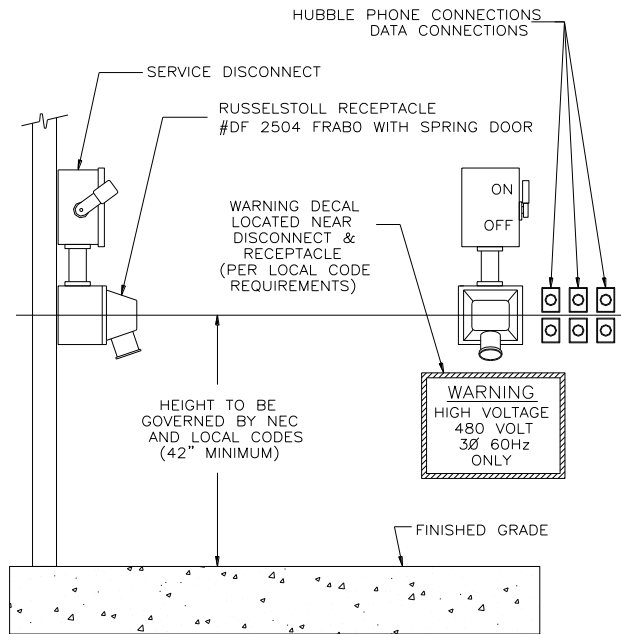

RECEPTACLE AND INSTALLATION PROVIDED BY CUSTOMER

DRAWN BY:

DRAWING NUMBER:
DET-0047

REV
1

Figure 6: Russellstoll Receptacle, Service Disconnect



Kentucky Trailer
 6370 Emerald Pkway, Ste.106
 Monee, IL 60449
 (708) 235-2800 main number
 (708) 235-2002 fax

Custom Specialty Vehicles



RUSSELLSTOLL RECEPTACLE CHART			
AMP / WIRE	DESCRIPTION		RECEPTACLE
	WIRES	POLES	PART NUMBER
MAXIMUM WIRE SIZE FOR LUG # 1/0	5	4	480 VOLT (200 AMP) 5 WIRE RUSSELLSTOLL RECEPTACLE DF 2504 FRABO THIS RECEPTACLE MUST BE WATERPROOF
480 VOLT AC DEDICATED POWER LINE FROM MAIN TRANSFORMER STATION	3Ø	WYE CONNECTION 150 AMP TOTAL 3Ø NEUTRAL AND GROUND	
RUSSELLSTOLL MATING PLUG PART# DS2504MP000/DF2032 5 WIRE/4 POLE 		MAIN DISCONNECT 3/N/PE AC 480 VOLT 150 AMP FUSED DISCONNECT 	
RECEPTACLE AND INSTALLATION PROVIDED BY CUSTOMER			DRAWN BY: DRAWING NUMBER: DET-0048 REV:

Figure 7: Russellstoll Receptacle Chart



Kentucky Trailer
 6370 Emerald Pkwy, Ste.106
 Monee, IL 60449
 (708) 235-2800 main number
 (708) 235-2002 fax

Custom Specialty Vehicles

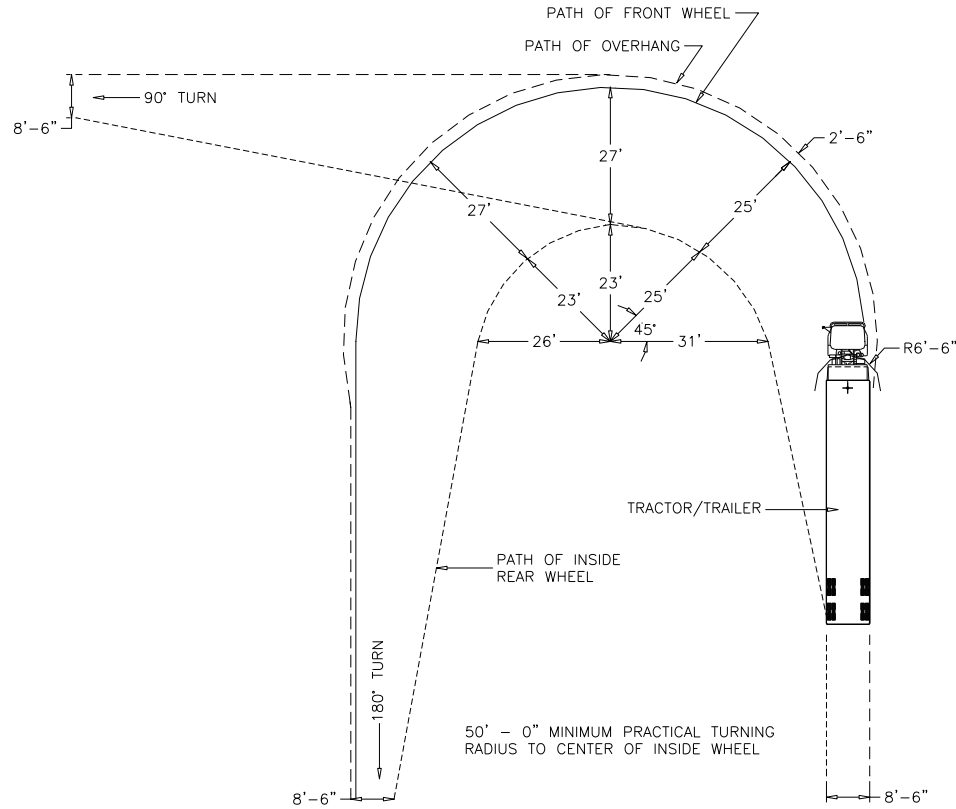

NOTE:
 HOSPITAL IS RESPONSIBLE TO
 ENSURE THE ACCESS ROUTE IS
 CLEAR OF OBSTRUCTIONS WHEN
 TRAILER IS SCHEDULE TO ARRIVE
 OR DEPART.

NOTE:
 THIS DRAWING IS A TYPICAL CONFIGURATION
 THE ACTUAL TURNING RADIUS WILL DEPEND
 ON TYPE OF TRACTOR, TRACTOR WHEEL BASE,
 FIFTH WHEEL PLACEMENT, ETC.

Figure 8: Turning Requirement