

REVISIONS					DESCRIPTION
REV.	REV. DATE	CHK. BY	CHK. DATE	ENG.	
01	09/05/08	T. BRUMMEL	09/05/08	D. ROZENDAL	REVISED LAYOUT PER QUENCH VENT & MEDICAL GAS DESIGN

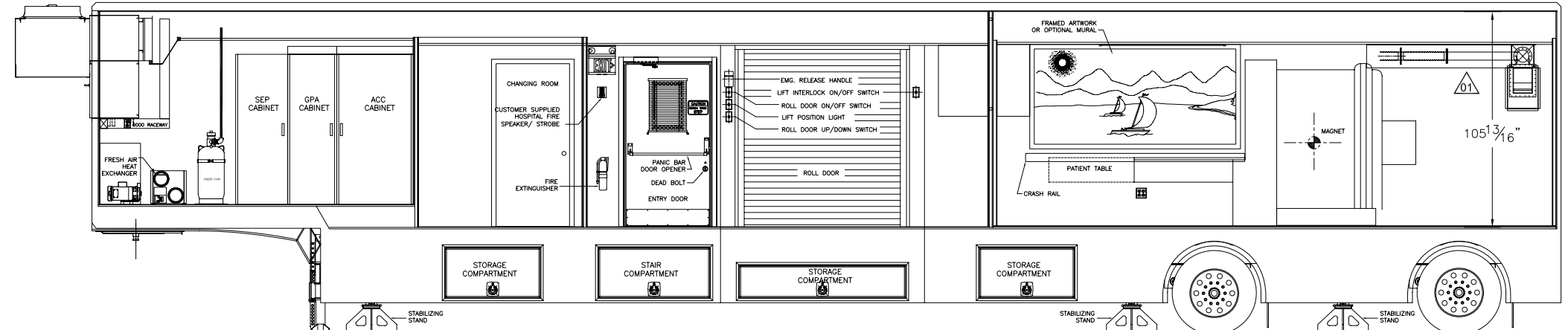

VIEW "B-B" RIGHT SIDE CROSS SECTION

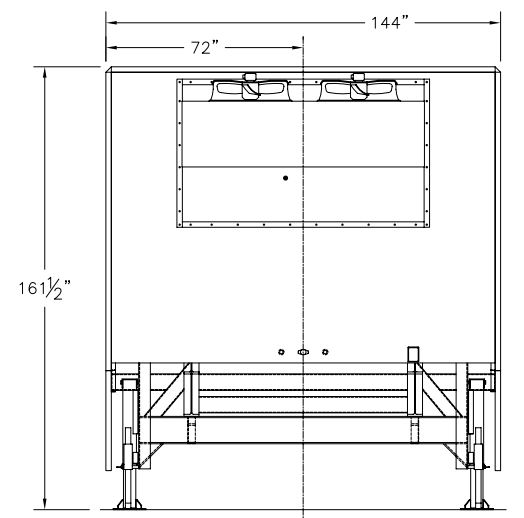

VIEW "C-C" EXTERIOR FRONT VIEW

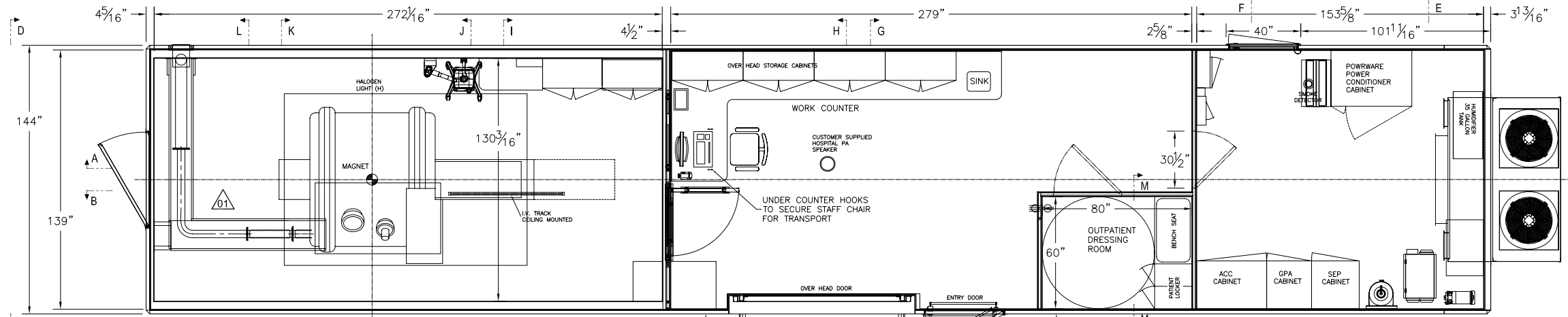

PLAN VIEW

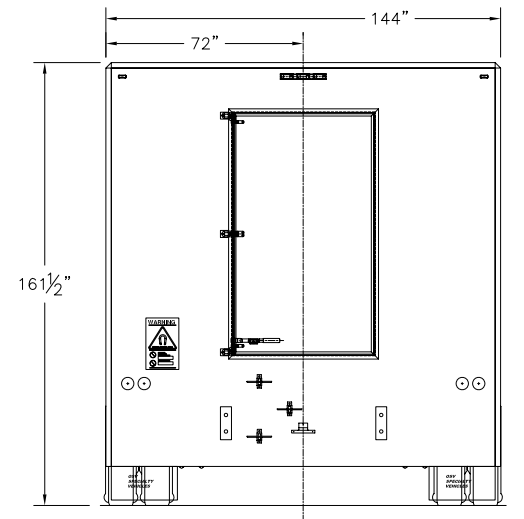

VIEW "D-D" EXTERIOR REAR VIEW

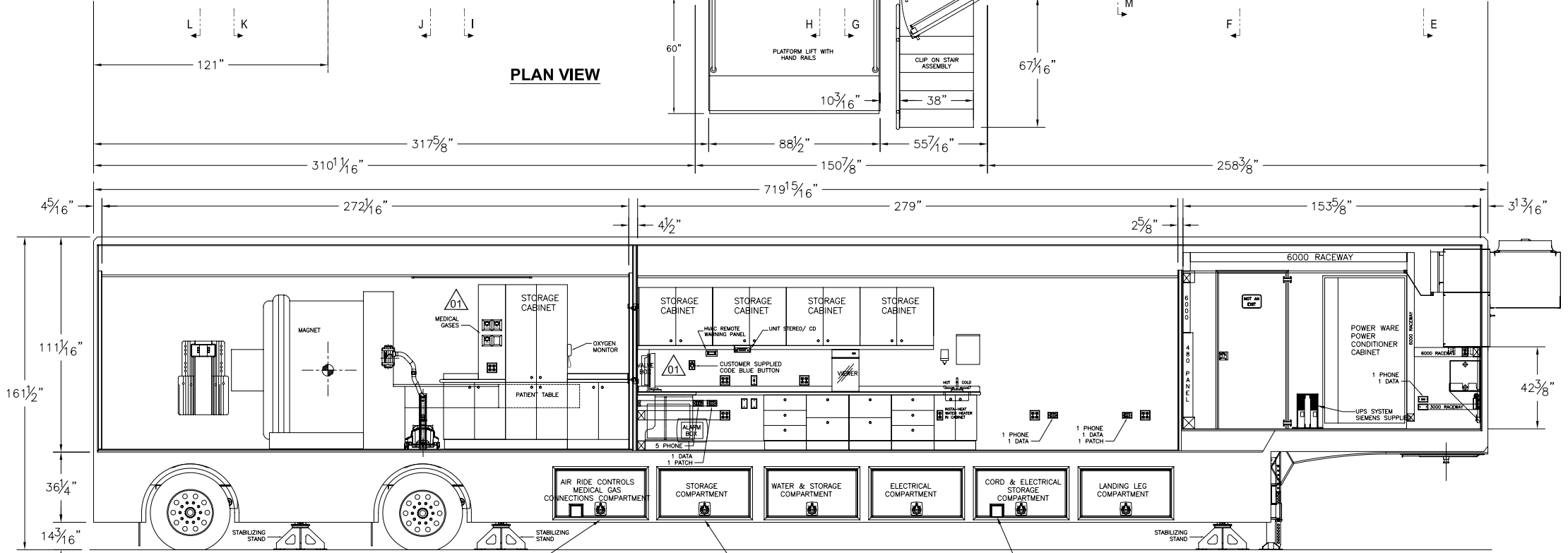

VIEW "A-A" LEFT SIDE CROSS SECTION

- GENERAL NOTES:**
1. CUSTOMER TO SUPPLY CODE BLUE BUTTON.
 2. CUSTOMER TO SUPPLY HOSPITAL PA SYSTEM SPEAKER.
 3. CUSTOMER TO SUPPLY HOSPITAL FIRE ALARM STROBE/BUZZER.
 4. CUSTOMER TO SUPPLY REGULATORS, VALVES, LOW PRESSURE WARNING DEVICES MANUALS, AND INSTRUCTIONS FOR THE MEDICAL GAS SYSTEM.

CUSTOMER AUTHORIZATION

COMPANY NAME: _____

NAME (PRINT): _____ TITLE: _____

SIGNATURE: _____ DATE: _____

- CONNECTIONS FOR:
1. OXYGEN
 2. MEDICAL AIR
 3. VACUUM
- 1/2" COPPER THREADED STUB FOR WATER DIRECT CONNECT (HUMIDIFIER & SINK)
- CONNECTIONS FOR:
1. CODE BLUE
 2. FIRE SUPPRESSION SYSTEM
 3. INTRUSION ALARM
 4. HOSPITAL PA SYSTEM
 5. HOSPITAL FIRE ALARM

THIS DRAWING IS PROVIDED ON A CONFIDENTIAL BASIS SUBJECT TO RETURN ON DEMAND OF OSHKOSH SPECIALTY VEHICLES ("OSHKOSH"), WHICH RETAINS ANY AND ALL RIGHTS ASSOCIATED WITH IT AND THE ARTICLE OR ARTICLES IT REPRESENTS. DISCLOSURE, REPRODUCTION OR ALTERATION OF ANY PART OF THIS DRAWING OR MANUFACTURE, USE OR SALE OF THE ARTICLE OR ARTICLES REPRESENTED, IS PROHIBITED WITHOUT THE PRIOR WRITTEN AUTHORIZATION OF OSHKOSH. © OSHKOSH SPECIALTY VEHICLES (unpublished).

SHEET NUMBER: SHEET 1 OF 2	REFERENCE DRAWING: P02252-A01-03	TITLE: AVANTO GENERAL LAYOUT SIEMENS MEDICAL SYSTEMS 1.0/ 1.5 T MRI 12'-0" x 13'-6" x 60'-0" TRANSPORTABLE	DATE: 06/10/08	SCALE: 3/8"=1'-0"
JOB#			DRAWN BY: D. ROZENDAL CHECKED BY: T. BRUMMEL DRAWING NUMBER: 10307-A01	
16745 S. LATHROP AVENUE HARVEY, IL, 60426 PHONE: (708) 596-5066 FAX: (708) 596-2480				